



New Zealand Institute of Architects Incorporated



Building Code Clause(s) B1

PRODUCER STATEMENT – PS1 – DESIGN

(Guidance on use of Producer Statements (formerly page 2) is available at www.engineeringnz.org)

ISSUED BY: TD STRUCTURES LTD
(Design Firm)

TO: Lifestyle Cabin Co Limited
(Owner/Developer)

TO BE SUPPLIED TO: Any Territorial Authority within New Zealand
(Building Consent Authority)

IN RESPECT OF: Meadow Solid Wood cabin 3.6X3m
(Description of Building Work)

AT: Various locations within NZ within the limitations of the schedule
(Address)

Town/City: LOT DP SO
(Address)

We have been engaged by the owner/developer referred to above to provide:
Structural design review of Meadow Solid wood cabin

(Extent of Engagement)

services in respect of the requirements of Clause(s) B1 of the Building Code for:

All or Part only (as specified in the attachment to this statement), of the proposed building work.

The design carried out by us has been prepared in accordance with:

Compliance Documents issued by the Ministry of Business, Innovation & Employment B1/VM1 or
(verification method/acceptable solution)

Alternative solution as per the attached schedule.....

The proposed building work covered by this producer statement is described on the drawings titled:

As per attached schedule and numbered ;
together with the specification, and other documents set out in the schedule attached to this statement.

On behalf of the Design Firm, and subject to:

- (i) Site verification of the following design assumptions as per attached schedule
- (ii) All proprietary products meeting their performance specification requirements;

I believe on reasonable grounds that a) the building, if constructed in accordance with the drawings, specifications, and other documents provided or listed in the attached schedule, will comply with the relevant provisions of the Building Code and that b), the persons who have undertaken the design have the necessary competency to do so. I also recommend the following level of construction monitoring/observation:

CM1 CM2 CM3 CM4 CM5 (Engineering Categories) or as per agreement with owner/developer (Architectural)

I, DAMIAN LINEHAN am: CPEng 1004738 # Reg Arch #
(Name of Design Professional)

I am a member of: Engineering New Zealand NZIA and hold the following qualifications: BE (Hons)

The Design Firm issuing this statement holds a current policy of Professional Indemnity Insurance no less than \$200,000*.

The Design Firm is a member of ACENZ:

SIGNED BY DAMIAN LINEHAN (Signature)

ON BEHALF OF TD STRUCTURES LTD Date 12/11/2021
(Design Firm)

Note: This statement shall only be relied upon by the Building Consent Authority named above. Liability under this statement accrues to the Design Firm only. The total maximum amount of damages payable arising from this statement and all other statements provided to the Building Consent Authority in relation to this building work, whether in contract, tort or otherwise (including negligence), is limited to the sum of \$200,000*.

This form is to accompany **Form 2 of the Building (Forms) Regulations 2004** for the application of a Building Consent.
THIS FORM AND ITS CONDITIONS ARE COPYRIGHT TO ACENZ, ENGINEERING NEW ZEALAND AND NZIA



Schedule to Producer Statement PS1

Job Title: Meadow Solid Wood Cabin 3.6x3m

Job #: 21149

12/11/2021

Lifestyle Cabins import the Meadow Solid Wood Cabin kitset cabin which falls under the category of a “single-story detached buildings up to 30m²” which are building consent exempt.

TD Structures have been engaged by lifestyle cabins to provide a design review of the Meadow cabins in accordance with the building consent exemption requirements.

The following schedule to the PS1 outlines the assumptions and documentation required for this review. It should be noted that any deviation from the requirements in this document will void this design certificate/producer statement.

Register of Documentation:

1. Lifestyle Cabins Assembly Instructions Meadow Solid Wood Cabin 3.6X3m
2. Parts list for the Meadow Solid Wood Cabin
3. TDS Design features report
4. TDS Additional fixing detail requirements

Design Assumptions:

1. Foundations and foundation connections (from provided bearers to chosen foundation solution) are assumed to be on “good ground” as per NZS 3604 and constructed in accordance with acceptable solutions provided within NZS 3604 2011.
2. No substitution with the products included in this design certificate is permitted.
3. Local authority and planning regulations should be confirmed by the owner prior to installation.
4. The installation will be carried out by a competent person with a thorough understanding of the building techniques required.

Durability: (NB: this Design certificate does not cover B2 Durability)

1. To maintain the timber and to extend the expected life of the individual elements, it is highly recommended that the timber walls be treated appropriately for their specific environmental exposure. Lifestyle Cabins have provided guidance in relation to this. Additionally, a coating specialist will be able to advise on this.
2. To maintain durability to the subfloor and foundations elements, the acceptable solutions within NZS 3604 are to be used.

Additional Requirements to the standard Installation:

1. Rafters to be nailed down into walls as per attached mark up
2. Door jambs and lintels to be fixed to wall sections as per attached mark up
3. Exterior braces to be fixed as per attached mark up
4. Floors to be screwed down to bearers as per attached mark up

TDS Job No: 21149

Date: 12-11-21

Author: DL

Reviewer: DL

These calculations pertain to Meadow Solid Wood Cabin 3.6X3m

at Various locations within the limitations detailed in the schedule and cover the following design aspects:

Superstructure design only of the timber cabins for wind, snow and Earthquake loads

IL = 1

Design life = 15 years with time to first maintenance (TTFM) of 5 years

Standards referenced

AS/NZS1170.2:2021 - Wind
 NZS 3603:1993 A1,2,4 - timber
 NZS 3604:2011 - timber buildings

Wind loads

NZS3604 Wind Zone Medium
 SED AS/NZS1170 - Quls 0.7 KPa

Snow loads

Sub alpine regions only

Structural form

Gravity:

Tongue and groove timber ceiling spanning between timber joists onto solid timber walls. Walls and floor span between timber bearers onto non-engineer designed 3604 type foundation solution.

Lateral Loads:

Timber walls span horizontally between return walls and/or door/window jambs. Door and window jambs span vertically to floor and/or composite lintel beam. At each exterior edge vertical battens provide mechanical anchorage from the roof to the floor so that the walls can act in plane. Fixings to the foundations resist overturning forces.

Permanent actions (dead loads) and live loads

Dead loads

	Roof	Floor	External walls	Internal walls
Description	lightweight roofing	timber framed floor	solid timber wall	solid timber wall
Unit load	0.25 kPa	0.2 kPa	0.25 kPa	0.25 kPa

Live loads (Refer table 3.1 & 3.2 Part 1 AS/NZS 1170)

	Roof	Floor	Deck	Garage
Distributed load	N/A	1.5 kPa*	N/A	N/A
Point load	N/A	1.8 kN	N/A	N/A

*Denotes reductions allowable in specific cases

Barrier loads N/A

Designed using requirements of clauses 3.6 and 3.8 of AS/NZS 1170.1 as modified by B1/VM1 (clauses 2.2.7 and 2.2.8) with imposed actions as specified in Table 3.3 of AS/NZS 1170.1.

Ductility

ductility = 3

Soil class and seismic coefficient

NZS 3604 bracing elements		SED bracing elements	
Soil class (cl.5.3.3)	D	Soil class =	D
EQ Zone (figure 5.4)	4	$S_p =$	0.93
		Cd type 1 element =	0.294
		Z =	0.13
		T_1	< 0.4 sec
		Cd type 2 element =	

Soil parameters

Shallow Footings - dependable bearing limit ($\phi=0.5$)	150	KPa
Pile Footings - dependable limit ($\phi=0.5$)end bearing	not applicable	KPa
skin friction	not applicable	KPa

Soil Type	ϕ (degrees)	Density (kN/m ³)	Expansive class type S, M or H to AS2870 or B1/AS1
Assumed good ground	N/A	N/A	N/A

Liquefaction risk (select from dropdown)

Low

Foundations

Standard slab on grade or ordinary piles as per NZS 3604

Corrosion

External areas

	Timber	Structural Steel	Concrete	Masonry
Zone	C NZS3604 Fig 4.2	N/A	B2 NZS3101, F3.1 T2	N/A
Provision	Treatment NZS3602, fixings NZS3604 T4.1	N/A	N/A	N/A

Sheltered areas

	Timber	Structural Steel	Concrete	Masonry
Zone	C NZS3604 Fig 4.2	N/A	A2 NZS3101, F3.1 T2	N/A
Provision	Treatment NZS3602, fixings NZS3604 T4.1	N/A	N/A	N/A

4:
Spax Washer head
screws
6mm X 160mm Long

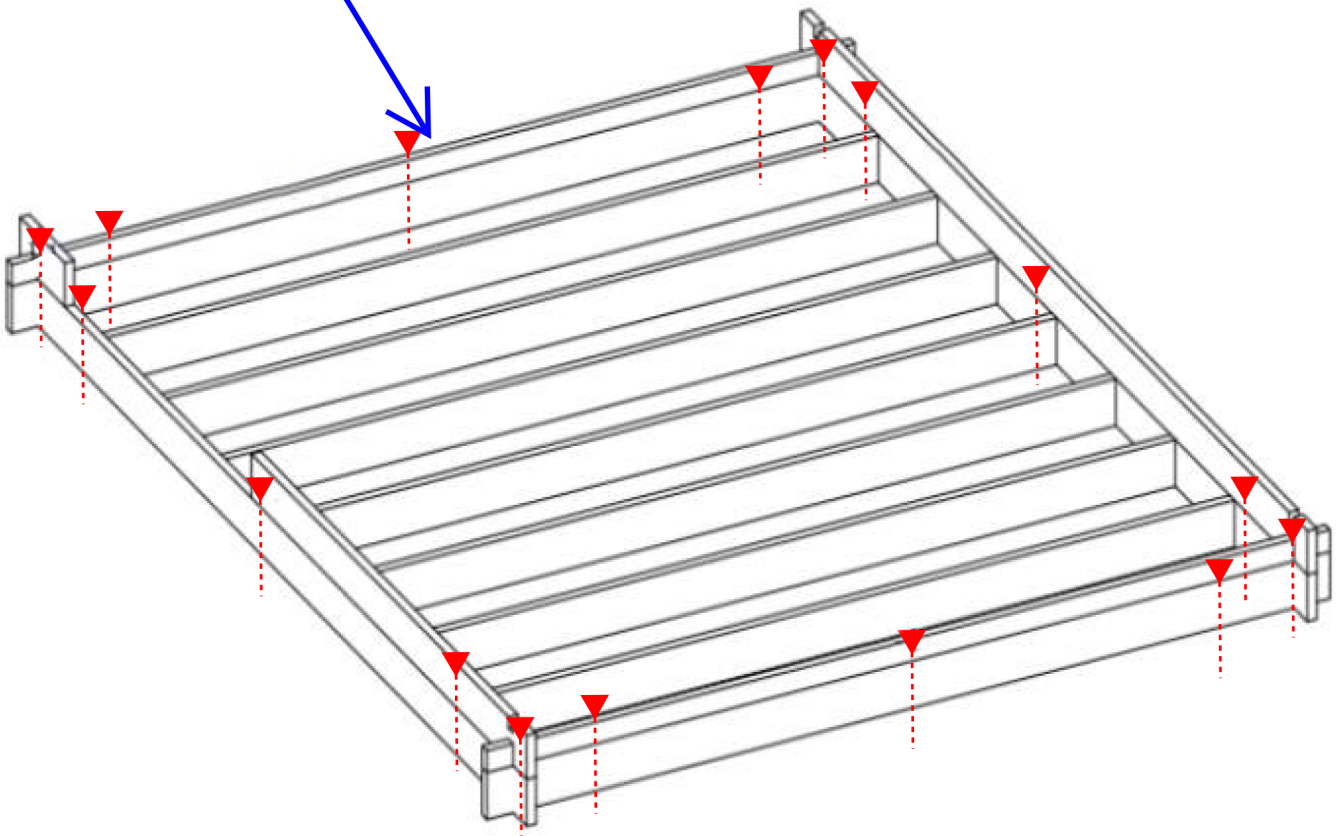

Meadow Cabin

SK1

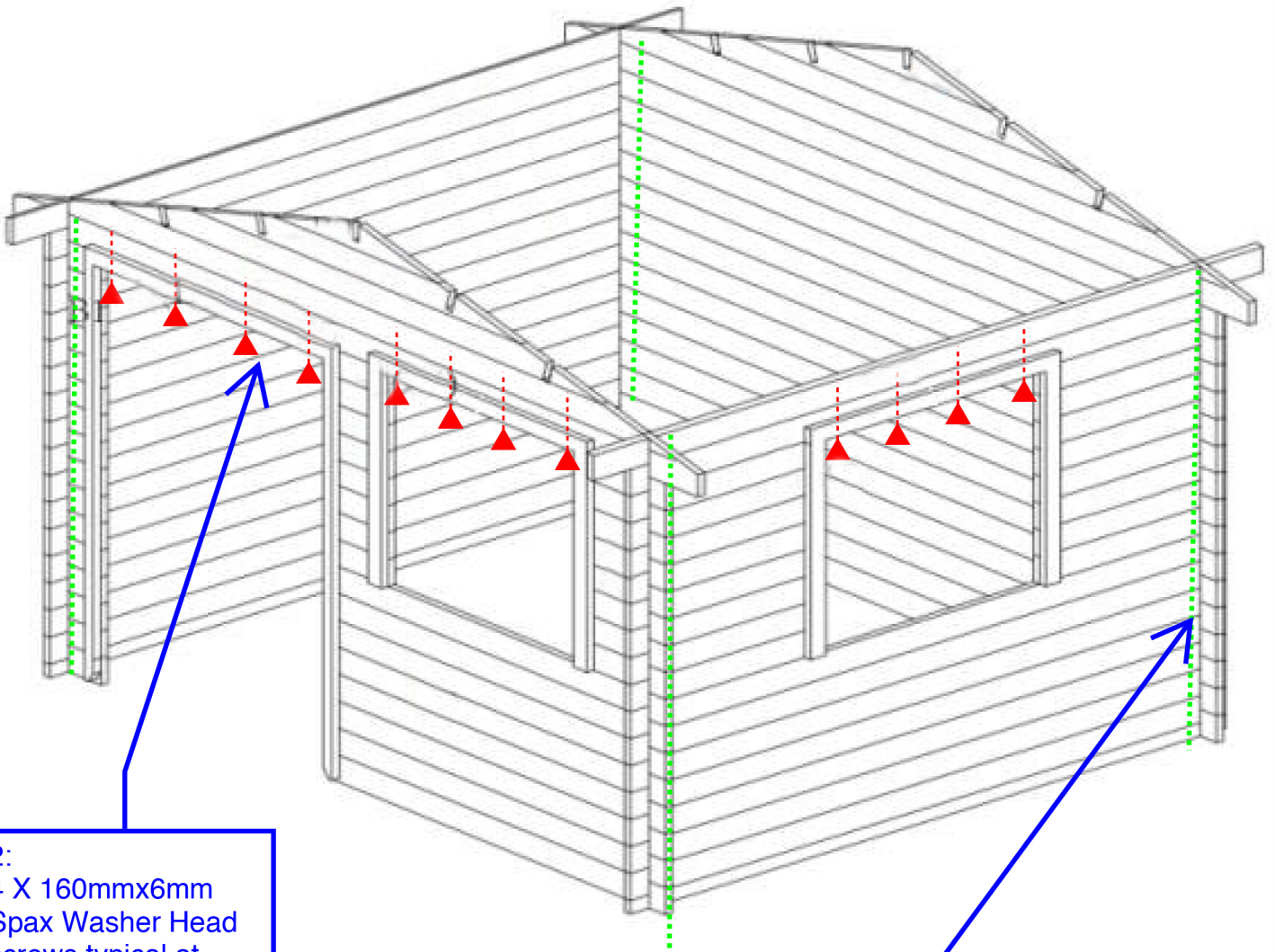

2:
4 X 160mmx6mm
Spax Washer Head
screws typical at
every lintel

3:
External braces shall
be nailed 2x2.8mm
Galv nails at each
timber section to
both sides



1:
Rafters to be nailed
down (2x2.8mm Galv
nails) at each rafter

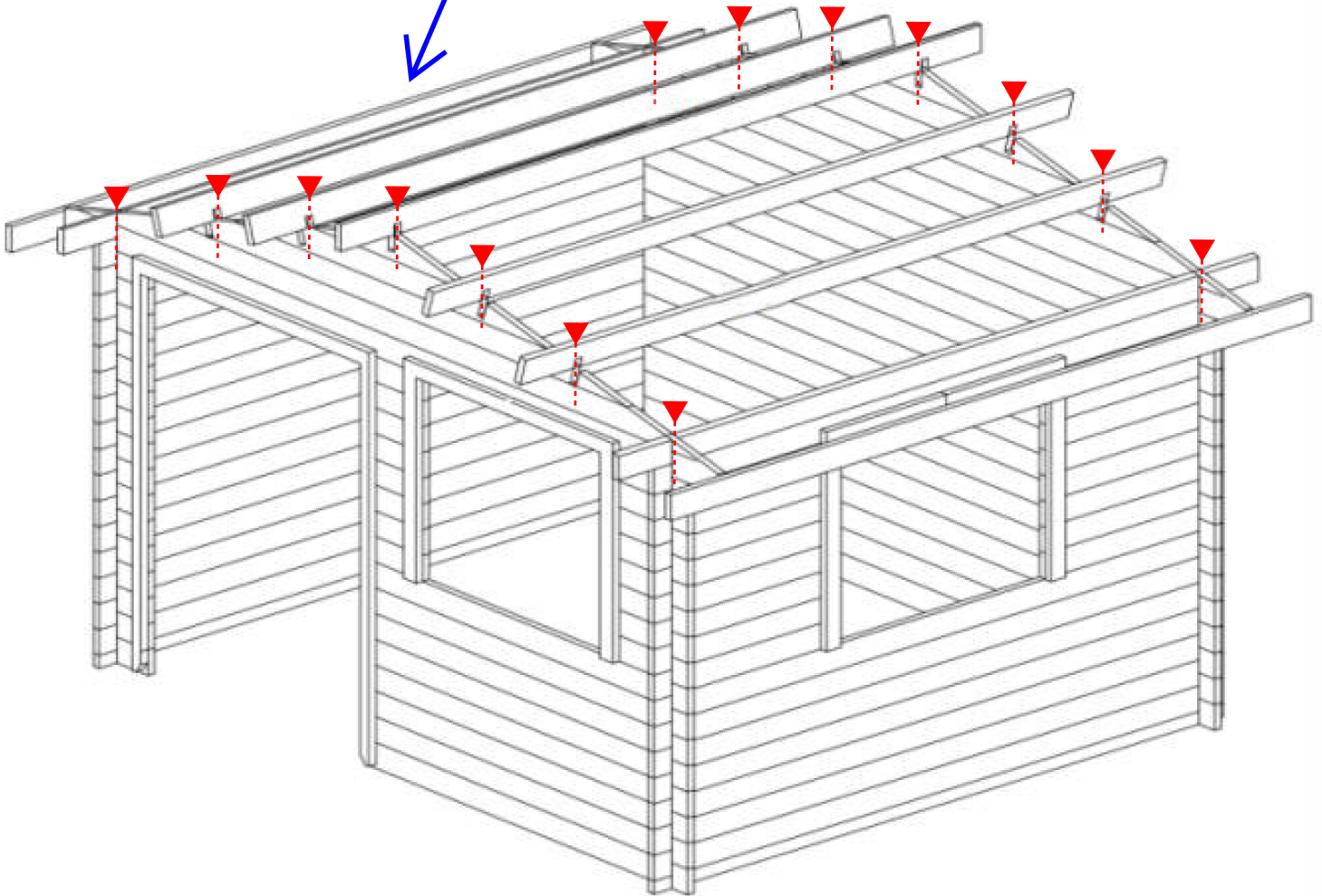

Meadow Cabin

SK3